

## HV Series - High Voltage Junction Boxes



3C-1

### Construction

- Available in (3) Materials: SS304, SS316L, Powder Coated (ASA61 Grey) Steel
- Folded Lip around the Door Opening to provide complete and maximum gasket seal
- Continuously Welded and Ground Smooth Seams
- Silicone Strip Gasket
- Welded on External Mounting Feet with 5/16" Clearance Holes/Slot
- External Door Clamps
- Continuous Piano Type Hinge with Removable SS Hinge Pin
- Ground Studs on Box and Cover
- Internal/External Earthing Lugs
- Universal Rail Mounting System
- Padlock Hasp & Staple for Padlocking

### Options

#### Gland Plates:

These removable plates offer great flexibility for the end user to drill holes without having to remove the entire enclosure from the installation site.

Add the following Suffixes:

- A: Gland Plate installed on top of box.
- B: Gland Plate installed on bottom of box.
- C: Gland Plate installed on left of box.
- D: Gland Plate installed on right of box.

For multiple gland plates omit dashes (*i.e.* HV4X-201407-**ABCD**)

#### Conduit/Cable Entries:

Entries can be provided per a customer sketch or with detailed information on the entry locations. Please refer to Entry Spacing Tables at the end of this section. *Note: This information is important and could affect the size of the enclosure you selected.*

#### Close-up Plugs:

Any unused entries must be plugged with a Certified Close-Up Plug. Adalet can provide close-up plugs in various styles and materials. Please indicate on the sketch or provide detailed information of holes to be plugged.

#### Enclosure Labeling:

Adalet can provide additional enclosure labeling with custom silk screening or various colors of Lamacoid™ nameplates. Please provide detailed information of the logo or text required.

#### Breather Drains:

Breather Drains can be provided per customer request. They are available in Brass or Stainless Steel 316L. Please indicate on a sketch or provided detailed information for locations.

#### Mounting Pans:





As an alternative to the universal rail mounting system, mounting pans are available in steel/powder coated, stainless steel, and aluminum. Please indicate when requesting quote.

## HV Series - High Voltage Junction Boxes

### General Information

Adalet's Single Door Clamped High Voltage Junction Boxes are available in Stainless Steel 316L & 304 and Carbon Steel. Silicone gaskets, removable hinge pin, box & cover ground studs including an internal/external earthing stud, and a universal rail mounting system are included as standard.



<b>Enclosure Certifications</b>		CE 0539 II 2GD EEx e II T6 (T5 Tamb +55°C) Ex e II T6 (T5 Tamb +55°C) Class I, Zone 1, AEx e II T6 (T5 Tamb +55°C) Class II, Division 2 IP66 Type 4, 4X (Stainless Steel only), 12, & 13	ATEX Directive 94/9/EC EN50014/EN50019 CSA E79-7, IEC 60079-7 UL 2279-7 UL 1604 IEC 60529 UL50	   
<b>Working Voltage</b>		AC	8kV Maximum	
<b>Material</b>		HV4 Series HV4X Series HV4X6 Series HV4 Series Gland Plates HV4X Series Gland Plates HV4X6 Series Gland Plates Universal Rail System Mounting Pan	#14ga Cold Rolled Steel, Polyester Powder Coated ANSI 61 Gray #14ga Stainless Steel 304, Brushed Finish #14ga Stainless Steel 316, Brushed Finish #10ga Cold Rolled Steel, Polyester Powder Coated ANSI 61 Gray #10ga Stainless Steel 304, Brushed Finish #10ga Stainless Steel 316, Brushed Finish 300 Series Stainless Steel #14ga Cold Rolled Steel, Polyester Powder Coated White	
<b>Gasket</b>			Silicone Sponge	
<b>Lid Fixing</b>	<b>Hinge</b>	HV4 Series HV4X Series HV4X6 Series	Continuous piano type - Steel with removable SS304 pin Continuous piano type - SS304 with removable pin Continuous piano type - SS316 with removable pin	
	<b>Door Clamps</b>	HV4 Series HV4X Series HV4X6 Series	Plated Steel Clear Stainless Steel 304 Stainless Steel 316	
<b>Enclosure Mounting</b>		All Types	Four (4) external lugs with .44" clearance holes/slots	
<b>Gland Plate Hardware</b>		All Types	300 Series stainless steel	
<b>Grounding</b>	<b>Box &amp; Cover</b>	All Types	1/4-20 Stud with 300 series stainless steel hardware	
	<b>Earthing Lugs</b>	All Types	#6-350MCM - Al/Cu	
<b>Impact Resistant</b>		All Types	7 Nm to EN50014/EN50019	
<b>Ambient Temperature Range</b>		All Types	-40°C to +55°C to EN50014	

3C-2

# HV Series - High Voltage Junction Boxes 1 x 1 Connection Series

## Shielded or Unshielded Cables

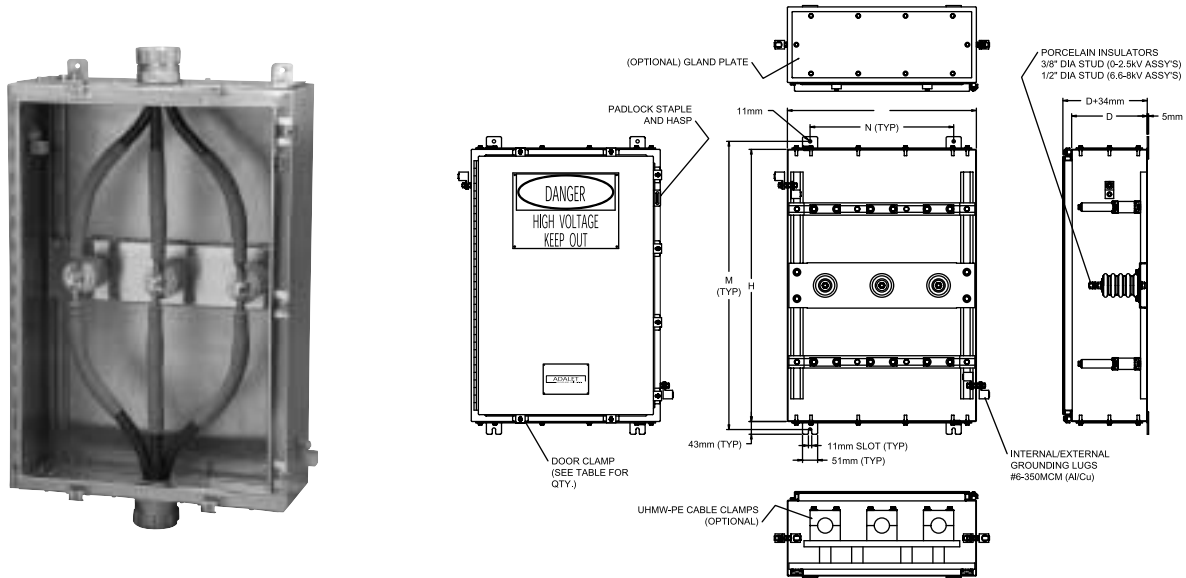

3C-3

SS316L CATALOG NUMBERS	H	W	D	M	N	Maximum Voltage	Maximum Amps (T5/T6)	# of Clamps
HV4X6-241206	610	305	152	664	241	1.5kV	315	5
HV4X6-242006	610	508	152	664	356	1.5kV	315	5
HV4X6-201206	508	305	152	562	241	2.5kV	250	4
HV4X6-161606	406	406	152	460	254	2.5kV	200	4
HV4X6-241606	610	406	152	664	254	2.5kV	315	5
HV4X6-301606	762	406	152	816	254	2.5kV	400	5
HV4X6-202006	508	508	152	562	356	2.5kV	250	4
HV4X6-201407	508	356	178	562	203	2.5kV	250	4
HV4X6-251807	635	457	178	689	305	2.5kV	315	5
HV4X6-302207	762	559	178	816	406	2.5kV	400	5
HV4X6-362507	914	635	178	968	483	2.5kV	400	8
HV4X6-201610	508	406	254	562	254	6.6kV	250	4
HV4X6-302010	762	508	254	816	356	8kV	400	5
HV4X6-242010	610	508	254	664	356	8kV	315	5
HV4X6-302410	762	762	254	816	458	8kV	400	5
HV4X6-242410	610	610	254	664	458	8kV	315	5
HV4X6-362410	914	610	254	968	458	8kV	400	5
HV4X6-362510	914	635	254	968	483	8kV	500	8
HV4X6-603610	1524	914	254	1578	762	8kV	500	9
HV4X6-603616	1524	914	406	1578	762	8kV	500	9

**Notes:**

1. For stainless steel 304 assemblies substitute HV4X6- prefix with HV4X- prefix.
2. For steel powder coated assemblies substitute HV4X6- prefix with HV4- prefix.
3. Please specify working voltage and amperage when requesting quote.
4. For conduit/cable entry spacing and minimum wire bending space requirements, refer to the end of this section.

**The Adalet Engineering Department is available to assist you in the selection of Increased Safety Enclosures.**

# HV Series - High Voltage Junction Boxes 2 x 2 Connection Series

## 2 Parallel Unshielded Cables

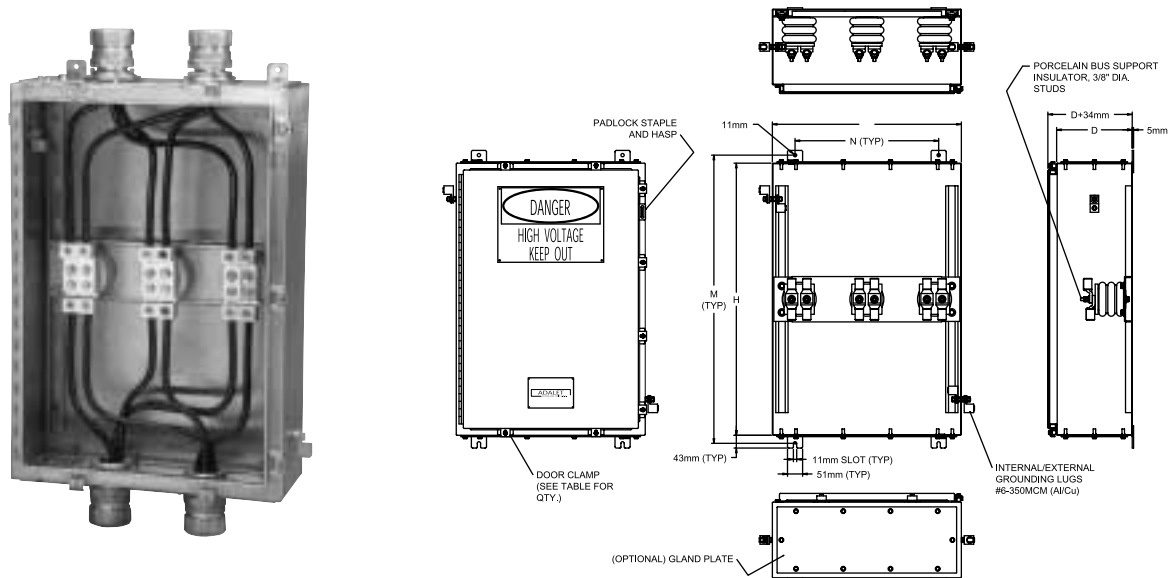

SS316L CATALOG NUMBERS	H	W	D	M	N	Maximum Voltage	Maximum Amps (T6)	Maximum Amps (T5)	# of Clamps
HV4X6-202008	508	508	203	562	356	1.1kV	500	500	4
HV4X6-242008	610	508	203	664	356	1.1kV	630	630	5
HV4X6-242408	610	610	203	664	458	1.1kV	630	630	5
HV4X6-202010	508	508	254	562	356	1.1kV	500	500	4
HV4X6-242010	610	508	254	664	356	1.1kV	630	630	5
HV4X6-302010	762	508	254	816	356	1.1kV	650	800	5
HV4X6-242410	610	610	254	664	458	1.1kV	630	630	5
HV4X6-302410	762	610	254	816	458	1.1kV	650	800	5
HV4X6-362410	914	610	254	968	458	1.1kV	650	800	5
HV4X6-362510	914	635	254	968	483	1.1kV	650	1000	8
HV4X6-603610	1524	914	254	1578	762	1.1kV	650	1000	9

**Notes:**

1. For stainless steel 304 assemblies substitute HV4X6- prefix with HV4X- prefix.
2. For steel powder coated assemblies substitute HV4X6- prefix with HV4- prefix.
3. Please specify working voltage and amperage when requesting quote.
4. For conduit/cable entry spacing and minimum wire bending space requirements, refer to the end of this section.

**The Adalet Engineering Department is available to assist you in the selection of Increased Safety Enclosures.**

3C-4



# Conduit/Cable & Wire Bending Guidelines

Table A - Minimum Spacing Between Centers of Conduit or Cable Entries

SIZE	NPT	5	4	3-1/2	3	2-1/2	2	1-1/2	1-1/4	1	3/4	1/2	1/16 ~ 3/8
NPT	METRIC	--	--	--	M75	M63	M50	M40	M32	M25	M20	M16	--
1/16 ~ 3/8	--	4-3/8 [112mm]	3-5/8 [92mm]	3-3/8 [86mm]	3 [77mm]	2-5/8 [68mm]	2-3/8 [61mm]	2 [51mm]	1-7/8 [48mm]	1-5/8 [42mm]	1-3/8 [35mm]	1-1/4 [32mm]	1-1/8 [29mm]
1/2	M16	4-3/8 [112mm]	3-5/8 [92mm]	3-3/8 [86mm]	3 [77mm]	2-5/8 [68mm]	2-3/8 [61mm]	2 [51mm]	1-7/8 [48mm]	1-5/8 [42mm]	1-3/8 [35mm]	1-1/4 [32mm]	
3/4	M20	4-1/2 [115mm]	3-3/4 [96mm]	3-1/2 [89mm]	3-1/8 [80mm]	2-3/4 [70mm]	2-1/2 [64mm]	2-1/8 [54mm]	2 [51mm]	1-3/4 [45mm]	1-1/2 [38mm]		
1	M25	4-5/8 [118mm]	3-7/8 [99mm]	3-5/8 [92mm]	3-1/4 [83mm]	2-7/8 [74mm]	2-3/4 [70mm]	2-1/4 [58mm]	2-1/8 [54mm]	1-7/8 [48mm]			
1-1/4	M32	4-7/8 [124mm]	4-1/8 [105mm]	3-7/8 [99mm]	3-1/2 [89mm]	3-1/8 [80mm]	2-7/8 [74mm]	2-1/2 [64mm]	2-3/8 [61mm]				
1-1/2	M40	5 [127mm]	4-1/4 [108mm]	4 [102mm]	3-5/8 [92mm]	3-1/4 [83mm]	3 [77mm]	2-5/8 [68mm]					
2	M50	5-3/8 [137mm]	4-3/4 [121mm]	4-1/2 [115mm]	4 [102mm]	3-5/8 [92mm]	3-3/8 [86mm]						
2-1/2	M63	5-1/2 [140mm]	4-7/8 [124mm]	4-5/8 [118mm]	4-1/4 [108mm]	3-7/8 [99mm]							
3	M75	5-7/8 [150mm]	5-1/4 [134mm]	5 [127mm]	4-5/8 [118mm]								
3-1/2	--	6-1/4 [159mm]	5-3/4 [147mm]	5-1/2 [140mm]									
4	--	6-7/8 [175mm]	6 [153mm]										
5	--	7-3/8 [188mm]											

This information is compiled from data which we believe is reliable and is given in good faith. Since the methods of application and condition under which our products are used are beyond our control, we are not able to guarantee the application and/or use of same. The user assumes all risks and liability in connection with the application and use of our products.

Table B - Minimum Distance from Conduit/Cable Center to Edge of Opening or Edge of Box

NPT	5	4	3-1/2	3	2-1/2	2	1-1/2	1-1/4	1	3/4	1/2	1/16 ~ 3/8
METRIC	--	--	--	M75	M63	M50	M40	M32	M25	M20	M16	--
	2-13/16 [72mm]	2-1/4 [58mm]	2 [51mm]	1-3/4 [45mm]	1-7/16 [37mm]	1-3/16 [31mm]	1 [26mm]	7/8 [23mm]	11/16 [18mm]	9/16 [14mm]	1/2 [13mm]	1/2 [13mm]

Table C - Minimum Wire Bending Space Between Terminals, Partitions, or Inside Walls

AWG	16	14	12	10	8	6	4	2	1/0	2/0	3/0	4/0	250	350	400	500
mm sq.	1.5	2.5	4	6	10	16	25	35	50	70	95	120	150	185	240	300
	1-1/2 [38mm]	1-1/2 [38mm]	1-1/2 [38mm]	1-1/2 [38mm]	2 [51mm]	3 [77mm]	3-1/2 [89mm]	5-1/2 [140mm]	6 [153mm]	6-1/2 [165mm]	7 [178mm]	8-1/2 [216mm]	10 [254mm]	12 [305mm]	13 [330mm]	14 [356mm]

**Notes:**

- The distances in Table A are recommended minimum distances between centers of conduit and cable gland entries. Consult manufacturer of conduit fitting or cable glands for their recommended minimum spacing.
- The distances in Table B are recommended minimum distances between center of conduit and cable gland entries to the edge of an opening or inside wall of box. Consult manufacturer of conduit fitting or cable glands for their recommended minimum spacing.
- The distances in Table C are the minimum wire bending space requirements between terminals, partitions, or inside walls.

3C-5

